



**COMPACT INTEGRATED
POWER STEERING**

Mount Pleasant Lane, Lymington, Hampshire SO41 8LS
Tel: +44 (0)1590 681445 Fax: +44 (0)1590 681446
www.hypromarine.com

INDEX

<u>Page No.</u>	<u>Contents</u>
1.	DESCRIPTION OF SYSTEM
2.	INSTALLATION <ul style="list-style-type: none">· General Preparation· Rudder Arm Preparation
3.	<ul style="list-style-type: none">· Mounting the HM2940 Power Cylinder/ Servo/Valve Assembly· Mounting the HM1820 Combined Reservoir/ Filter/Cooler Assembly
4.	<ul style="list-style-type: none">· Mounting the Power Pump(s)
5.	<ul style="list-style-type: none">· Mounting the Helm Unit· Pipework Installation
6.	<ul style="list-style-type: none">· Purging the Manual Portion of the System
7.	<ul style="list-style-type: none">· Purging the Power Circuit
8.	APPENDIX A – HM4400 Reservoir with Integral Autopilot Supply
9.	AUTOPILOT CONTROL VALVE
10.	PREVENTATIVE MAINTENANCE <ul style="list-style-type: none">· Every 30 days or before Usage of Vessel· Every 6 months
11.	<ul style="list-style-type: none">· After One Year or First 50 Hours· After Two Years or 300 Hours
12.	TROUBLESHOOTING

DRAWINGS

HM1820A	HM3108/NV	HM4400
HM2940	HM4155	HM4546
HM3008/NV		

DESCRIPTION OF SYSTEM

The HYPRO MARINE Integrated Power Steering System comprises two distinct hydraulic circuits as illustrated on drawing HM4155:-

- a. A hand operated manual system which provides the control.
- b. A power circuit to carry out the working duty.

The manual (control) part operates as a standard hydraulic steering, with the helm(s) supplying oil to either side of the servo cylinder which is part of the HM2940 Power Cylinder/Servo/Valve Assembly. The servo cylinder commands the power cylinder to follow its movement. The power cylinder thus operates in direct response to helm(s) movement, to give a high response steering with minimal wheel effort.

The power cylinder assembly provides AUTOMATIC return to manual wheel steering if power pump flow is not available. The helm pumps include relief valves which limit the pressure in the manual steering circuit to 1000psi.

The HM1820 Combined Reservoir/Filter/Cooler Assembly provides oil for the hydraulic power pumps(s). The power pump(s) can either be driven directly from one or both of the main engines, a generator, or by a suitable electric motor. The system is suitable for operation using either controlled flow or, alternatively, fixed displacement power pump(s). The output flow of fixed capacity power pump(s) to the steering circuit is controlled by the HM1813 (for two pumps) or alternatively HM1844 (for single pump) Relief/Flow Control Assembly. These can be close coupled to the Reservoir Assembly. A separate filtered connection from the reservoir provides the reference supply of oil to the helm unit(s).

In operation, pressure is only developed in the power circuit to bring about changes in rudder position. Under steady conditions the power pump(s) circulate oil freely in the power circuit. At all times, oil in the power pump circuit is being filtered, and the oil cooler ensures that correct operating temperatures are maintained.

INSTALLATION

GENERAL PREPARATION INSTRUCTIONS

1. It is recommended that prior to starting any work installing the system, the contents of this manual are fully considered.
2. Before commencing installation, check all components have been received and that all installation fittings are available.
3. It is recommended that fittings are made to component ports prior to installation. In the case of taper threads we would recommend the use of a suitable thread sealant “Loctite 542 Hydraulic Sealant” or equivalent. This sealant should be used sparingly, and care taken to ensure that it does not enter the system. Do not use thread sealant on connections made to hydraulic tube, or hose fittings.
4. It is recommended that all system components are installed prior to running the system tubing. This not only allows the tubing to be run between definite positions, but minimises the chance of incorrect pipework connections. If pipework needs to be pre-installed then an effective means of marking and preventing contaminant entering the system should be adopted. Pipework should be cut cleanly, and it is good practice to blow through each line with clean compressed air before connections are made.

CLEANLINESS IS EXTREMELY IMPORTANT

5. Pipework should be routed to prevent damage from any moving parts or on machinery removal etc. Avoid running pipework close to hot areas, i.e. adjacent to exhaust systems or turbo-chargers. Pipework should be adequately supported and secured avoiding sharp edges or dissimilar metals.

RUDDER ARM PREPARATION

1. The HM2940 Power Cylinder/Servo/Valve Assembly has a nominal operating stroke of 9”.
2. The following chart defines tiller arm radius/required rudder angle.

Rudder Arc	Rudder Arm Length
80°	6.625”
70°	7.437”
60°	8.5”
50°	10.125”

3. Ensure that the attachment bolt or pin to be used matches the ball joint provided on Power Cylinder of the HM2940 unit. Drill and ream the hole in the rudder arm to ensure a close fit.

MOUNTING THE HM2940 POWER CYLINDER/SERVO/VALVE ASSEMBLY

1. In mounting the HM2940 Cylinder Assembly it is important to ensure that a free passage exists for the flexible hoses which connect to it. In operation these hoses should not be obstructed, or come into contact with any other part.
2. Ensure that the tiller arm can operate freely through its intended angle of operation. When connected to the tiller arm the Cylinder Assembly must be unobstructed throughout the full angle of travel.
3. With the steering cylinder rod attached to the rudder arm, the mounting foot should be positioned such that the HM2940 unit will operate horizontally. When viewed from above it should lie crosswise to the boat when the tiller arm is midway between dead ahead and maximum hard over.

NOTE: Care should be taken not to damage the cylinder rod as leakage could result.

4. The mounting bracket to which the HM2940 unit will be connected should have sufficient strength to withstand the forces in operation. The unit can produce a thrust up to 2700 lbs (1230kgs).
5. The specification of the flexible hose used to connect to the unit must provide for a working pressure of at least 1500 PSI.

MOUNTING THE HM1820 COMBINED RESERVOIR/FILTER/COOLER ASSEMBLY

1. Select a mounting position which will not create a length of suction pipework to the power pump, greater than is necessary. The position chosen should allow for easy fluid filling and air charging, and give convenient access to check fluid level and air precharge in operation. Pipework is minimised if the mounting position can be between the engine(s) and the HM2940 unit.

2. The suction hose from the Combined Reservoir to the power pump should have a minimum $\frac{3}{4}$ " bore diameter, and be capable of resisting collapse under a vacuum condition.
3. The oil cooler requires a water flow rate of approximately 3-4 GPM.
4. It is recommended that installation fittings for both water and hydraulic oil circuits are made before mounting the HM1820 unit.
5. For those steering circuits which incorporate two fixed capacity power pumps, an HM1813 Power Pump Conditioning Valve is required. For single power pump installations, the HM1844 is used. The supply of the power pumps is connected through ports 'P1' 'P2' of the HM1813, or port 'P' of the HM1844 valve. Pressure hose(s) used must provide for a working pressure of at least 1500psi.

MOUNTING THE POWER PUMP(S)

1. If a controlled flow pump is used, it should provide a nominal regulated flow of approximately 2.5 GPM, and limit the operating pressure to 1000psi. The speed at which it is driven should ensure that full controlled flow is available at a nominal engine speed of 1200 RPM and that sufficient flow is available for steering at engine idle.
2. The power pump will typically require a peak input power of 2 HP. For a pulley drive, an 'A' or 'B' section belt can be used.
3. In the case of pulley drives, the mounting bracket for the pump should adequately support the pump, ensure pulley alignment and provide for belt tensioning. The suction and pressure ports of the power pump should be accessible.
4. For direct power pump drive from the main engine, ensure that the power take-off provides the correct rotation, and that the pump will provide the correct flow at the power take-off speed.
5. For the electric motor drives, ensure that the capacity of the pump is matched to the electric motor speed. In sizing the electric motor it should be remembered that the peak power required during steering manoeuvres is approximately 2 HP. The pump is operated in an unloaded condition when no steering is called for.

MOUNTING THE HELM UNIT

1. The helm unit may be mounted in any position (ensuring fill plug to top) or angle that is best suited to the installation. It is preferable if ports and fittings can be installed facing downwards.
2. Clockwise rotation of the helm shaft gives output of flow from the 'S' port, and anti-clockwise, the 'P' port. The connection from 'R' is made to the appropriate reservoir connection. Port sizes are 1/4" NPTF.
3. Ensure that when installed, the helm shaft does not bind on or interfere with the mounting panel.

PIPEWORK INSTALLATION

1. In considering the installation, ensure that suitable hoses are incorporated into the system to allow for movement of the power pump(s) and the HM2940 Cylinder Assembly. Pressure hoses should be rated for a working pressure of at least 1500psi.
2. In choosing rigid tubing for the installation, it is important to consider compatibility of this with the material of construction of the vessel. If flexible hose is to be used for the complete installation, due consideration must be given to the specification of the hose selected to provide minimum expansion of the hose under pressure.

3. Pipe Sizes

Typical for boats up to 65ft length:

Steering	5/16" bore*
Power	1/2" bore
Suction to power pump	3/4" bore
Reservoir reference	5/16" bore or 3/8" OD for nylon tube.

- * Selection of hose to provide minimum expansion under pressure is important.

If in doubt on sizing of pipework, please refer to Hypro Marine.

4. After all connections are made, it is recommended that the reservoir is charged to 20psi air pressure. DO NOT ADD OIL TO THE SYSTEM AT THIS TIME. Observe the pressure gauge for loss of pressure which would be an indication of leaks in the system. A soapy solution can be used to identify suspect fittings.

AT THIS POINT, DO NOT START THE ENGINES OR RUN THE POWER PUMP(S).

PURGING THE MANUAL PORTION OF THE SYSTEM

1. Remove the air/oil filler plug from the top of the oil reservoir. Fill the reservoir to within 2” of filler neck with oil of the recommended specification. We would normally recommend the use of Shell Tellus R10 or an equivalent. Pressurise the reservoir to 20psi.
2. Verify that the oil level in the reservoir does not drop below 2” from the bottom of the sight tube. Refill and pressurise until the level stabilises at a point half way up the sight tube.
3. Partially open fill plug at lowest helm until fluid appears and re-tighten. Repeat at successive higher stations.
4. Check the reservoir oil level and refill and pressurise as necessary.
5. Commence with HM2940 in a fully retracted position, and bleed tube connected between far end of small cylinder and purging nipple on valve block. Open bleed nuts approximately one turn.
6. At the highest helm, turn the wheel slowly (1-2 revs per sec) for approximately 60-70 turns whilst preventing the cylinder from extending. Ensure that the wheel is being operated in a direction which would extend the cylinder. Repeat this procedure with the same wheel direction for successive lower stations. If a separate autopilot is fitted to the system, operate this in an extending direction for approximately 30 seconds. Close bleed nuts. **From any helm, fully extend the cylinder.**

7. Repeat step 6, but with the bleed tube between the other side of the small cylinder and valve block, and the cylinder in the extended condition. Turn the wheel(s) and autopilot in the opposite direction. Close bleed nuts.

AT ALL TIMES WHILST CARRYING OUT STEPS 6 - 7, ENSURE THAT THE OIL REMAINS WITHIN 2" OF THE BOTTOM OF THE SIGHT TUBE.

8. Operate helm at any position to each end of stroke to verify a definite stop is achieved. It is beneficial to operate the wheel beyond the normal end stop for approximately half a turn to verify the operation of the relief valves incorporated in the system.

PURGING THE POWER CIRCUIT

1. Start the power pump(s), observing the fluid in the reservoir. If it drops to within 2" of the bottom of the sight tube, shut down pump(s), refill the reservoir, re-pressurise and re-start the pump(s).
2. From any helm, slowly steer hard-over to hard-over several times. This will essentially self purge the power portion of the system.
3. To verify that the system is purged, advance throttle(s) to approximately 1200 RPM. For systems incorporating a 2 cu.in. capacity helm unit there should be approximately 3.5 turns from hard-over to hard-over. If significantly greater, the power pump(s) should be shut down and the above sequence for purging the manual portion of the system repeated.
4. Re-check the reservoir oil level and fill if necessary to $\frac{1}{2}$ - $\frac{3}{4}$ full. Re-pressurise to 20psi. Check again after 24 hours to verify that pressure and fluid levels are being maintained.
5. To visually observe any future leakage, it is best to mark the stabilised fluid level on the sight tube.

In normal operation there should be no contact with the rudder stops. Rudder stops should be set to have a nominal $\frac{1}{8}$ " operating clearance, set at both full hard-over positions, with the system in the power mode.

APPENDIX A

HM4400 Combined Reservoir With Integral Autopilot Supply

This unit is a derivative of the HM1820 Reservoir and is illustrated on circuit HM4546.

It provides a controlled flow of oil taken from the power pump supply, to be made available for autopilot control. Its inclusion in the system prevents the need for a separate electric motor driven autopilot pump and its associated electrical power supply.

The solenoids on the HM4400 only require 28 watts as autopilot control signals.

AUTOPILOT CONTROL VALVE

It may be necessary to set the response rate of the servo cylinder when under pilot control.

It is usual to give an approximately 10 second lock to lock time (please refer to pilot manufacturers requirement).

To adjust the response rate remove adjuster cap and, using a flat blade screwdriver, turn adjuster clockwise to slow the response and anti-clockwise to increase response.

Refit locking cap and tighten.

PREVENTIVE MAINTENANCE

Every 30 Days or Before Usage of Vessel

1. Check hydraulic fluid level, which should be between $\frac{1}{2}$ and $\frac{3}{4}$ full on the sight gauge. There may be a small reduction in level during operation of the system which should recover shortly after shutdown.
2. Check pre-charge pressure in reservoir – this should be approximately 20psi. There may be variation in this pressure due to temperature and operational changes. Pre-charge, as with oil level, should be checked preferably prior to engine start-up.

Note

There should be no concern unless the pre-charge pressure drops below 10psi. If this loss is over an extended period, re-pressurise to 20psi. This loss may be compared to that which one experiences with a good set of automotive tyres over an extended time. Should the pressure loss be over a relatively short period:

- a. Check there is no leakage of oil in the system. Rectify if necessary. Refill and re-pressurise.
- b. Check for air leakage.

Every 6 Months

1. Check fluid level in the reservoir.
2. Check pre-charge in the reservoir.
3. Check pivot points in the system are suitably greased or oiled. The HM2940 unit is provided with a grease maintenance point.
4. Check mounting bolt of steering unit tiller arm, and rear mounting bolts to vessel structure are correctly tightened.

5. Ensure that the ball joint on HM2940 unit is operating freely and is suitably greased. It is suggested that if a tie bar is fitted on the vessel, this is checked at this point.
6. Ensure that there is no wear in either the ball joint or the rear pivot mounting of the HM2940 unit.
7. Check all hoses on the installation for possible chafing or scuffing against one another, or against part of the vessel. Replace if braiding under the rubber sheath is exposed.
8. If power pump(s) are belt driven, check belt for wear and proper tension. Replace as required.

After One Year or First 50 Hours

Additional to 6 month check, replace the micro filter cartridge and refill system oil as necessary.

THE RESERVOIR PRE-CHARGE MUST BE RELIEVED BEFORE CHANGING FILTER CARTRIDGE.

After Two Years or 300 Hours

Additional to 6 month check, replace micro filter cartridge and carry out complete oil change to the system. Re-purge power circuit. Refer to P.7 "Purging the Power Circuit".

TROUBLESHOOTING

PROBLEM	POSSIBLE CAUSE	SOLUTION
One helm unit will operate the rudder, but the other has no effect.	1. Air lock at helm. 2. Contaminant in pilot check valve of correctly functioning helm.	1. Crack fittings at helm. 2. Replace or have repair carried out on the helm.
Operation at one helm causes other station helm to operate.	Contaminant in pilot check valve of free-wheeling helm unit.	Replace or have repair carried out on the free-wheeling helm.
Rudder will not retain set position.	Leaking in relief valve (manual circuit).	Carry out manual system purging to displace possible contaminant. Alternatively, refurbish helm pumps.
System appears not purged after commissioning.	Air saturation in oil.	Re-purge after reasonable settling period.
Power pump(s) noisy in operation.	Suction cavitation at pump(s).	Suction hose restriction or excessive length. Increase size of suction hose if length cannot be reduced.
Steering locks at hard-over.	Excess friction in servo.	Grease, lubricate, or correct possible off-set loading.
Operation of one helm gives opposite command to the other.	Helm ports 'P' and 'S' cross connected at one helm station.	Reverse pipe connection to 'P' and 'S' at the station(s) that is in error.
Operation at helm(s) gives incorrect steering direction.	Helm(s) ports 'P' and 'S' cross connected with 'H1' and 'H2' of HM2940	Reverse pipe connections 'H1' and 'H2' at HM2940.
Helm(s) pumps in one direction but not in the other.	1. Symptom at one helm indicates helm fault. 2. Symptom at both helms indicates valve fault in HM2940	1. Replace or have repair carried out on the helm. 2. Check purging valve is fully closed. If so, refurbish HM2940 valve.
Helm unit(s) give excessive turns for lock to lock.	Air in system.	Re-purge system.
Loss of fluid and pressure in the reservoir.	Leak in the system.	Check all connections. Repair as necessary. For direct engine drive pump(s), shaft seal leak may not be directly evident. Check.
Loss of pressure with no loss of reservoir fluid.	Air leak in upper portion of reservoir.	Check free air connections of reservoir with soap solution test. Rectify. Leakage at pressure gauge may be difficult to identify.
Pump(s) overheat.	Excess pressure relieving usually associated with controlled flow pump(s)	Reconsider steering circuit to provide separate relief return line piped through oil cooler.

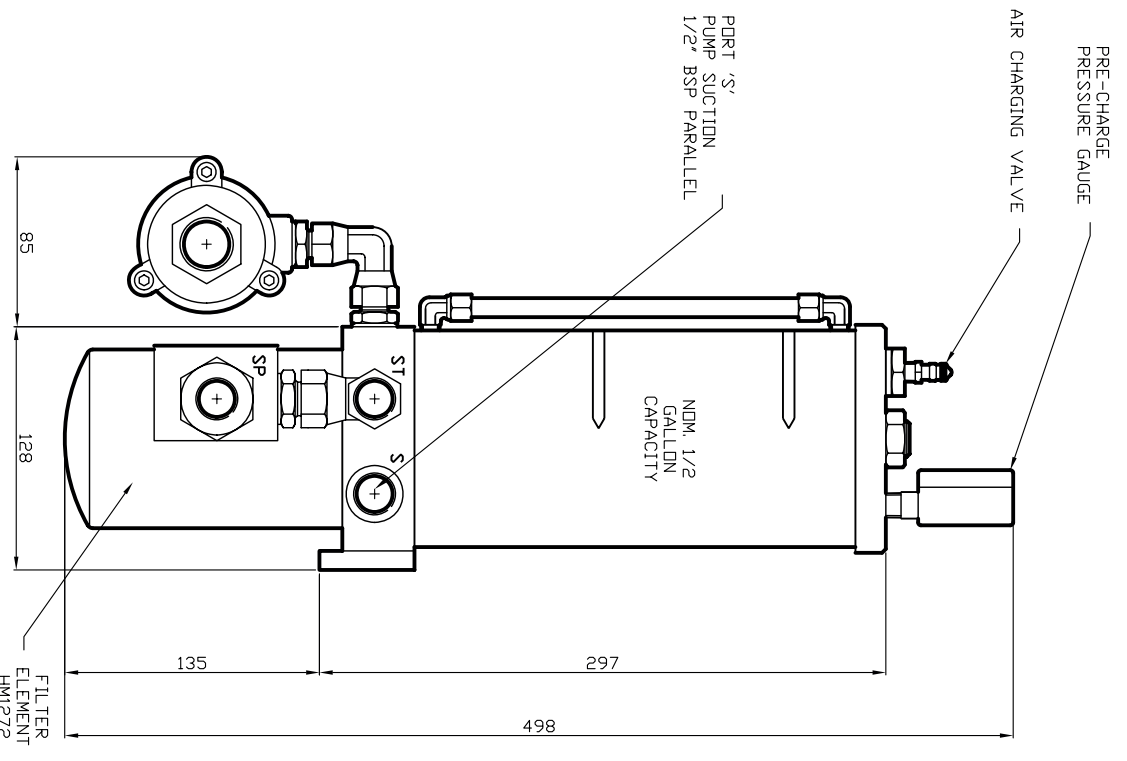
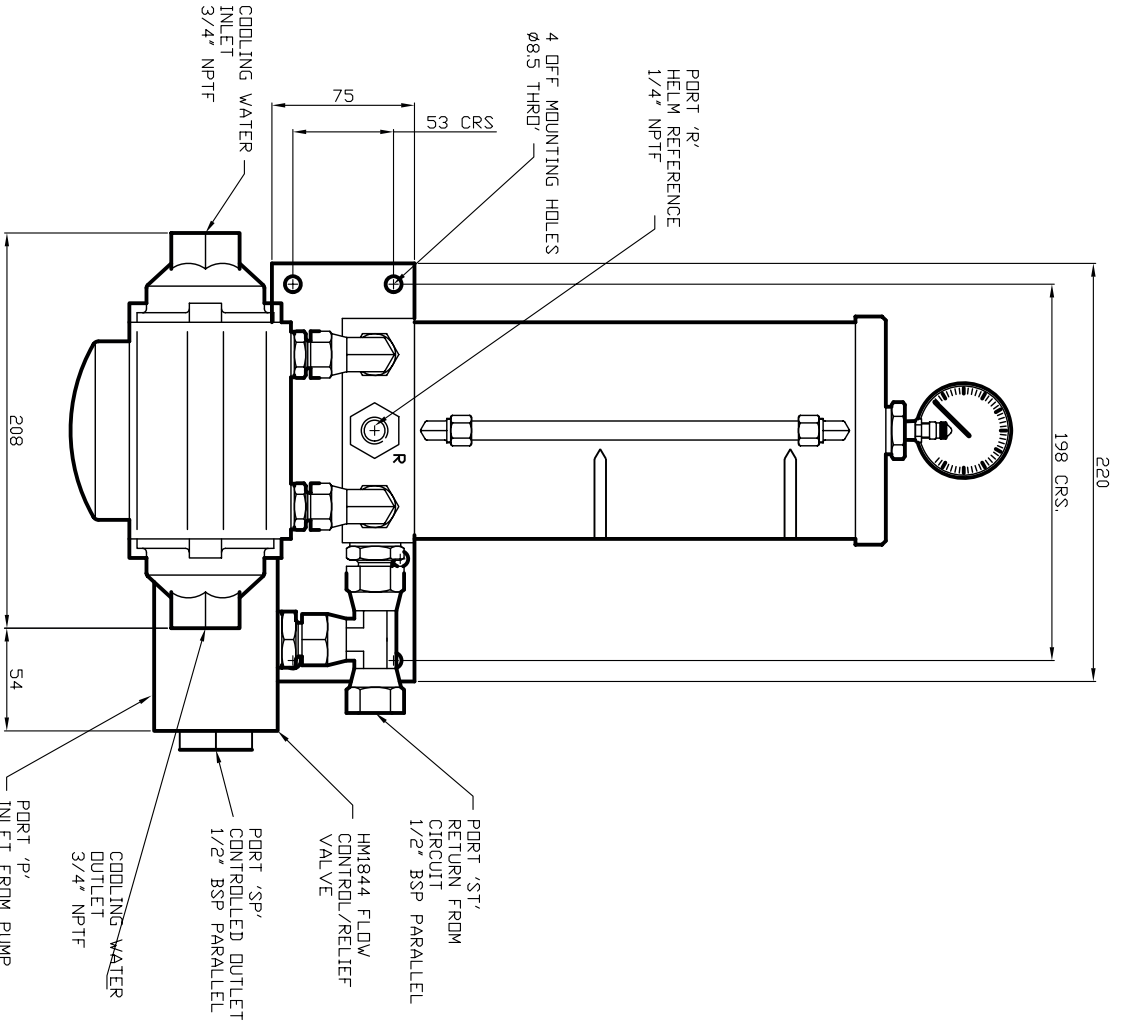

THIS DRAWING IS THE PROPERTY OF HYPRO MARINE AND MUST NOT BE COPIED IN WHOLE OR PART WITHOUT WRITTEN CONSENT

HYPRO MARINE

TITLE

RESERVOIR ASSEMBLY
C/W FLOW CONTROL/RELIEF VALVE

ISSUE

ALT. NO

DRAWN

DRG. NO

1

ORIGINAL

MC

HM1820A

2

2/5/03

DATE

2/7/02

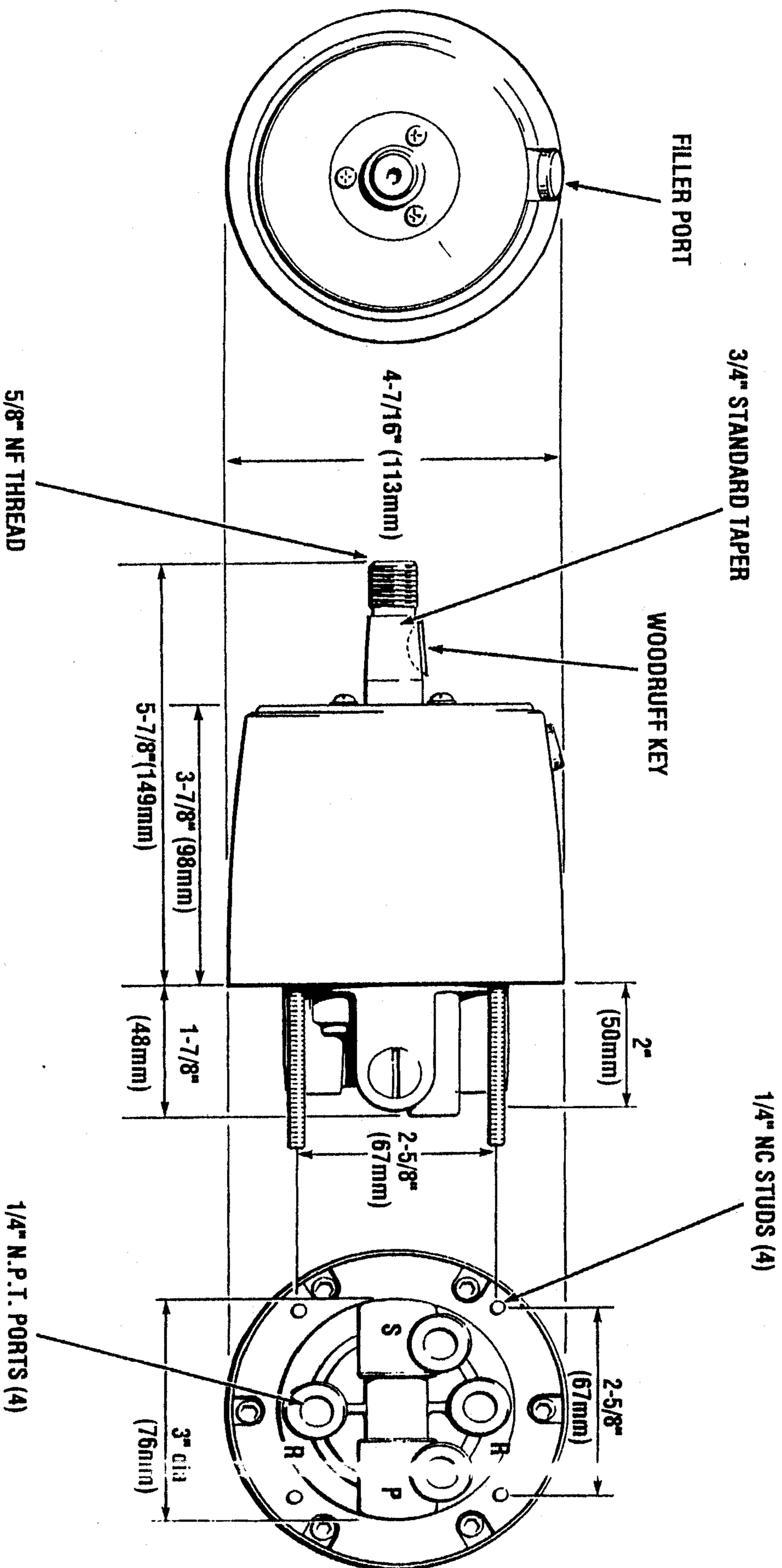

HYPERBOLIC MARINE

TITLE

2.0 cu.in. FIXED HELM

ISSUE

1

ALT No.

ORIGINAL

DRAWN

DE

DATE

29.9.99

DRG No

HM3008/NV

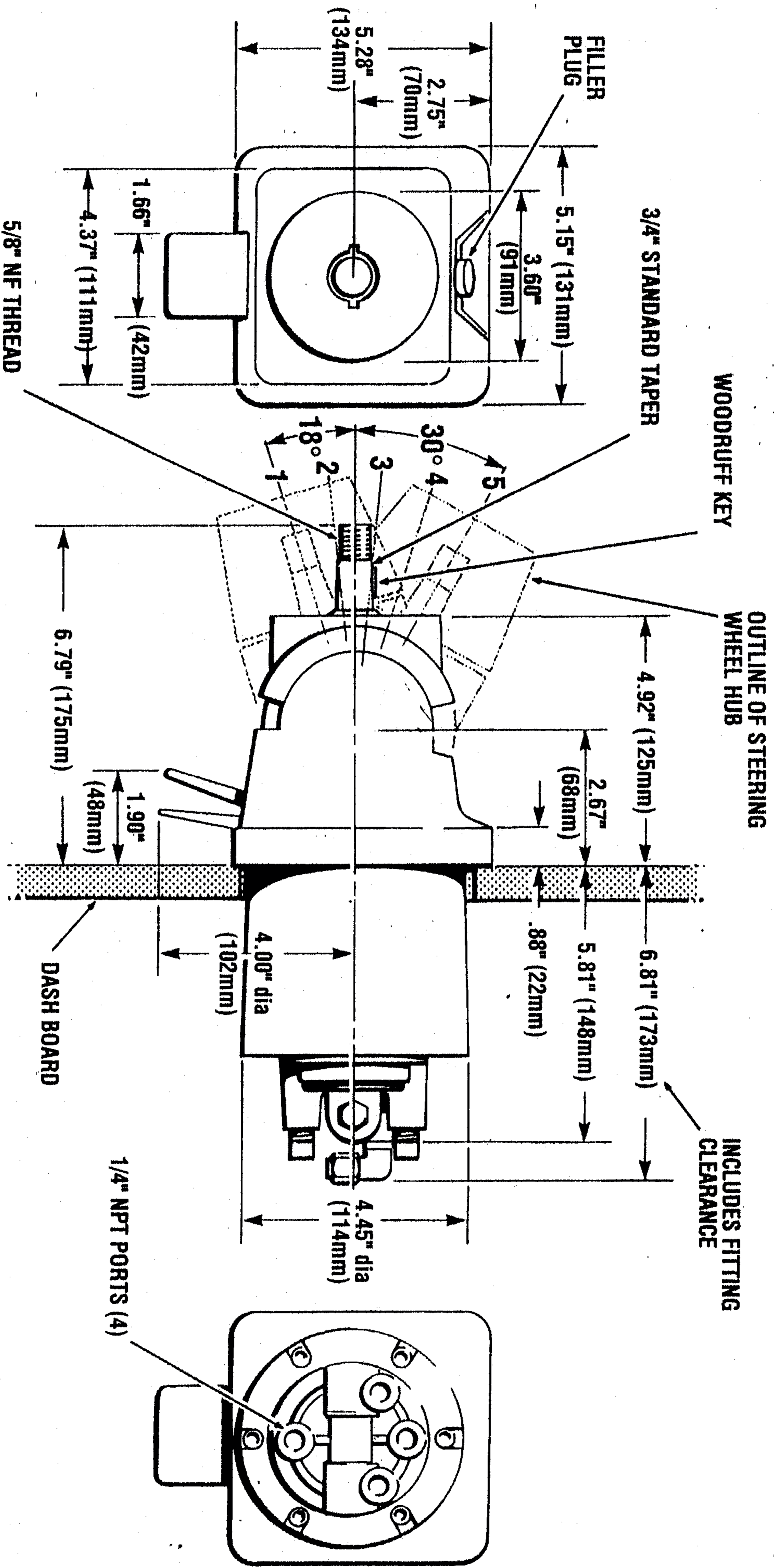

HYPRO MARINE

TITLE

2.0 cu.in. TILT HELM

ISSUE

1

ALT No.

ORIGINAL

DRAWN

DE

DRG No

HM3108/NV

DATE

29.9.99

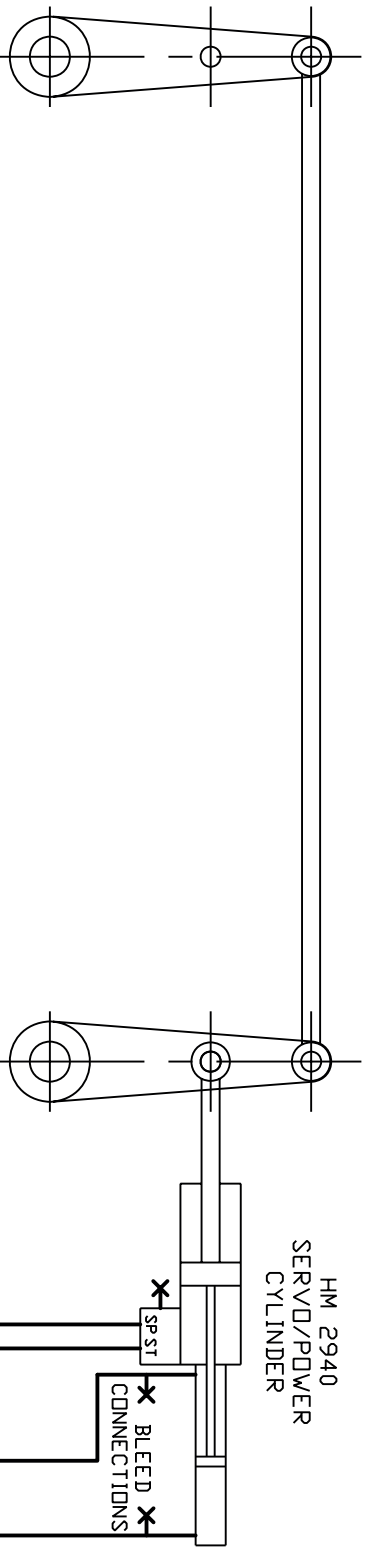

THIS DRAWING IS THE PROPERTY OF HYPRO MARINE AND MUST NOT
BE COPIED IN WHOLE OR PART WITHOUT WRITTEN CONSENT

TITLE

HYDRAULIC STEERING CIRCUIT
ECONOMY POWER STEERING

ISSUE ALT. NO

DRAWN M.C.
DATE

5/4/00

DRG. NO

HM4155

HYPRO MARINE

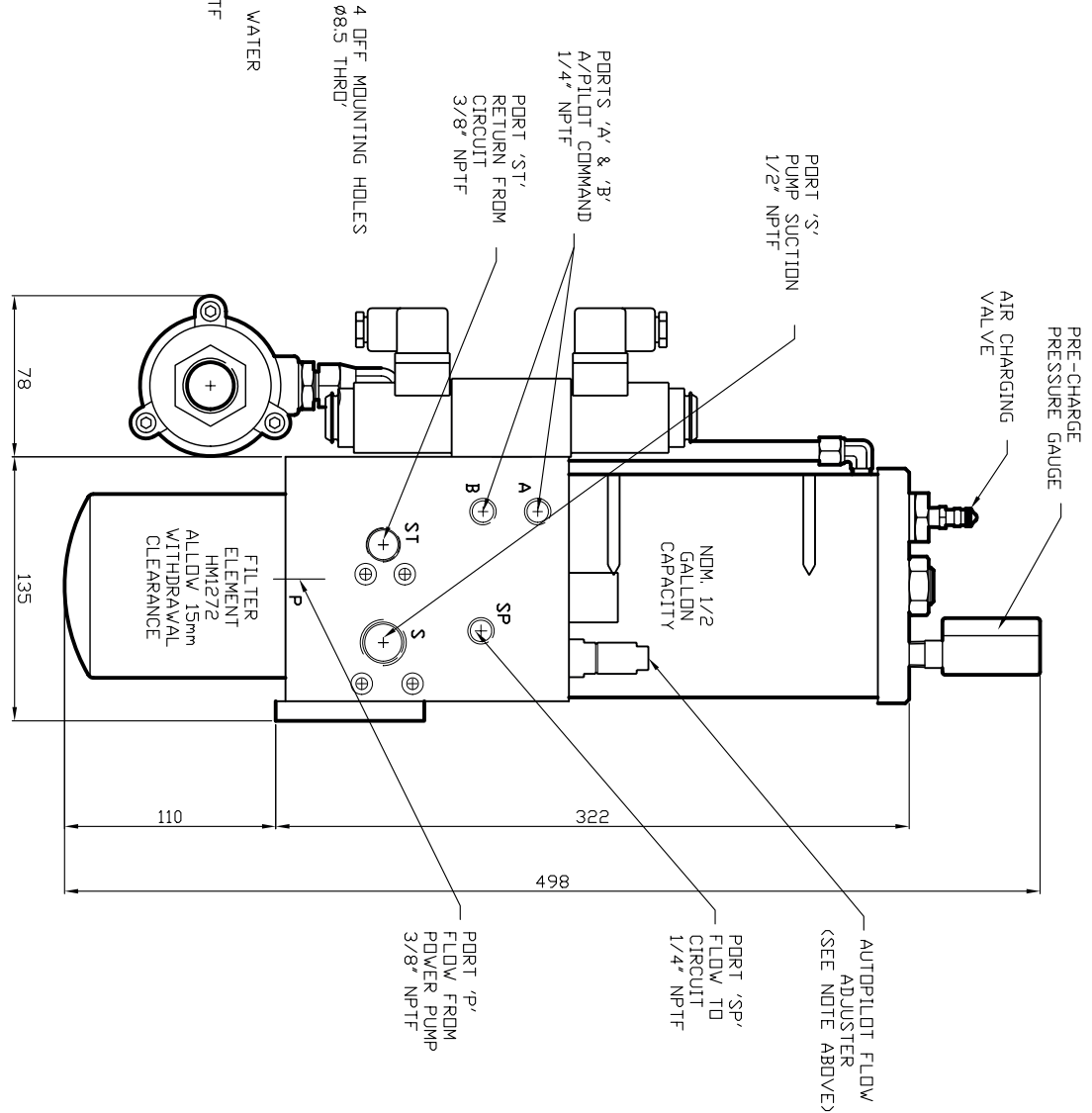
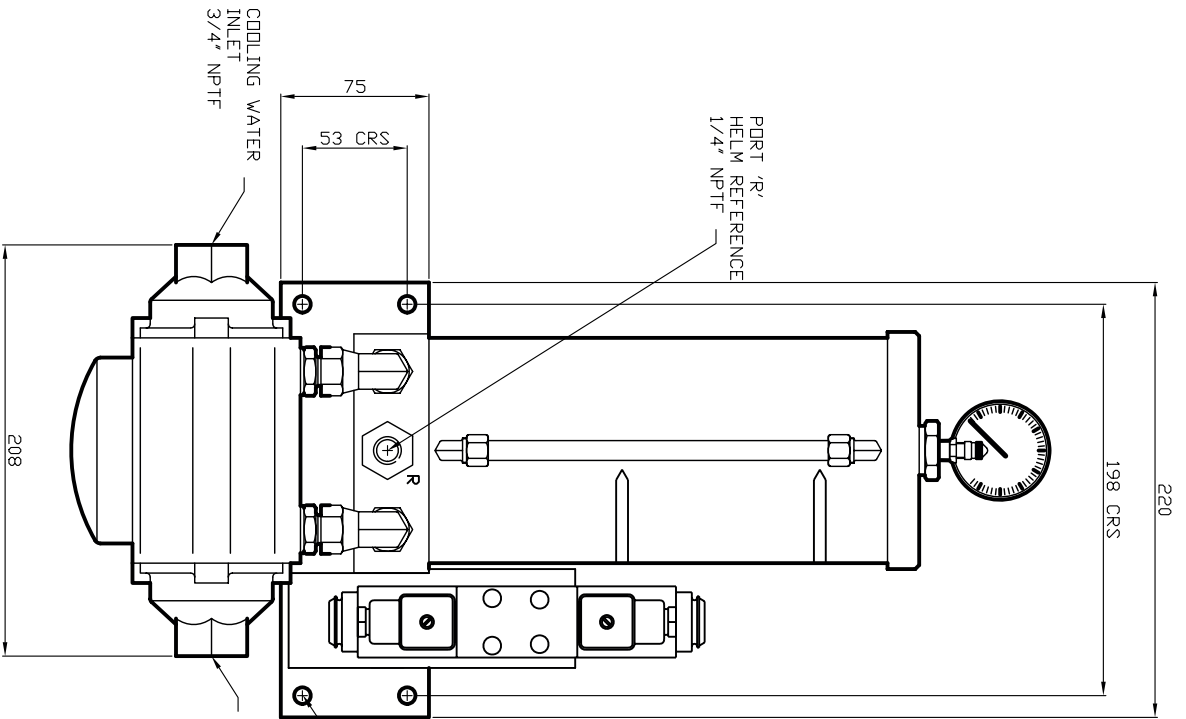

TO ADJUST AUTOPILOT RESPONSE TIME, REMOVE CAP AND TURN ADJUSTER CLOCKWISE TO DECREASE FLOW, (INCREASE LOCK TO LOCK TIME), AND VISE VERSA.

THIS DRAWING IS THE PROPERTY OF HYPRO MARINE AND MUST NOT BE COPIED IN WHOLE OR PART WITHOUT WRITTEN CONSENT

HYPRO MARINE

TITLE

RESERVOIR ASSEMBLY

ISSUE	ALT. NO	DRAWN	DRG. NO
1	ORIGINAL	MC	HM4400
		DATE	
		2/7/02	

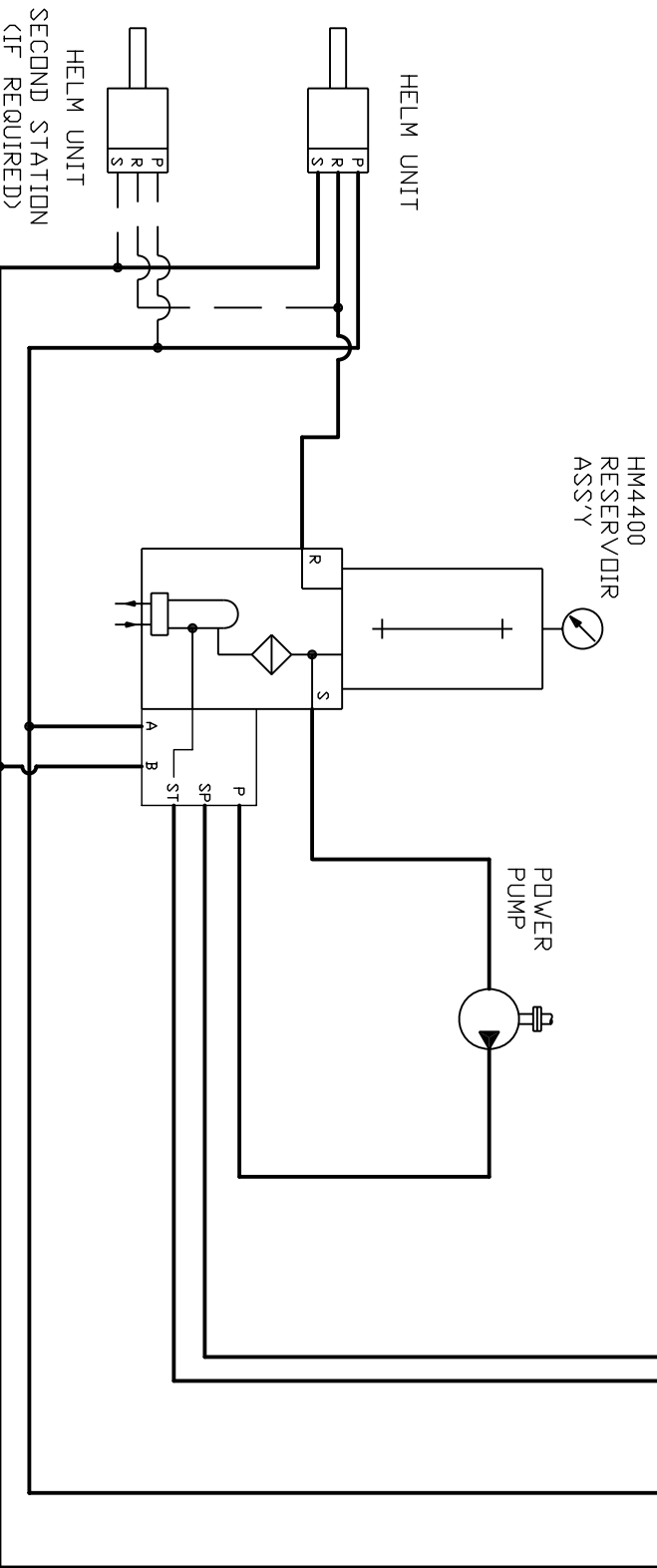
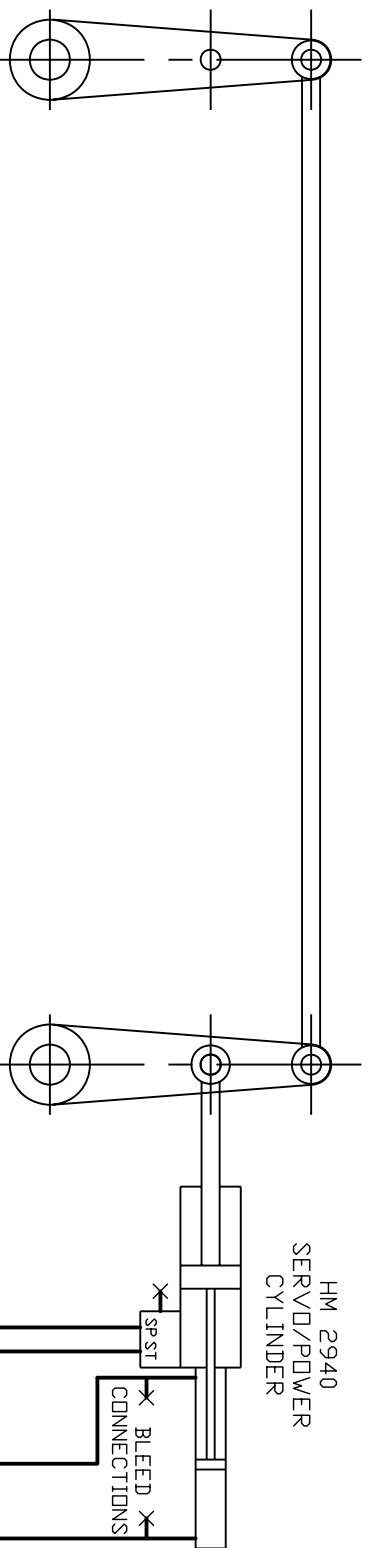

THIS DRAWING IS THE PROPERTY OF HYPRO MARINE AND MUST NOT
BE COPIED IN WHOLE OR PART WITHOUT WRITTEN CONSENT

TITLE

HYDRAULIC STEERING CIRCUIT
ECONOMY POWER STEERING-
WITH BUILT-IN AUTOPILOT

ISSUE

ALT. NO

DRAWN
M.C.

DRG. NO

DATE

5/2/03

HM4546

HYPRO MARINE